

Carvel[®]

ice cream bakery



model 770C



model 771C

operator's manual



Taylor Distributor: _____

Address: _____

Phone: _____

Service: _____

Parts: _____

Date of Installation: _____

© December, 1991 Taylor
All Rights Reserved
044732-M



*The word Taylor and the Crown design
are registered trademarks in the United States
of America and certain other countries.*

Taylor Company
750 N. Blackhawk Blvd.
Rockton, IL 61072



Contents

To the Installer	2
To the Operator	3
Data Plate	4
Safety	5
Warranty	6
Controls and Panels	7
Specifications	9
Operator Parts Identification	11
Important: To the Operator	14
Operating Procedures	16
Important: Operator Checklist	24
Operator's Troubleshooting Guide	25
Parts Replacement Schedule	28
Parts List	29
Wiring Diagram	34
Service To Keep Inside Back You Serving	Cover



To the Installer

These machines are designed for indoor use only.



DO NOT install the machine in an area where a water jet could be used to clean or rinse the machine. Failure to follow this instruction may result in serious electrical shock.

WATER CONNECTIONS (Water Cooled Units Only)

An adequate cold water supply must be provided with a hand shut-off valve. On the underside rear of the base pan, two 1/2" I.P.S. water connections for inlet and outlet have been provided for easy hook-up. 1/2" inside diameter water lines should be connected to the machine. (Flexible lines are recommended, if local codes permit.) Depending on local water conditions, it may be advisable to install a water strainer to prevent foreign substances from clogging the automatic water valve. There will be only one water "in" and one water "out" connection. **DO NOT** install a hand shut-off valve on the water "out" line! Water should always flow in this order: first, through the automatic water valve; second, through the condenser; and third, through the outlet fitting to an **open trap drain**.

AIR COOLED UNITS

The Model 770C requires a minimum of 3" (76 mm) of clearance around **all** sides of the freezer and the Model 770C requires a minimum of 6" (152 mm) of clearance around **all** sides of the freezer to allow for adequate air flow across the condensers. Failure to allow adequate clearance can reduce the refrigeration capacity of the freezer and possibly cause permanent damage to the compressor.

ELECTRICAL CONNECTIONS

Each freezer requires one power supply for each data label. Check the data label on the freezer for fuse, circuit ampacity and electrical specifications. Refer to the wiring diagram provided inside of the electrical box, for proper power connections.

In the United States, this equipment is intended to be installed in accordance with the National Electrical Code (NEC), ANSI/NFPA 70-1987. The purpose of the NEC code is the practical safeguarding of persons and property from hazards arising from the use of electricity. This code contains provisions considered necessary for safety. Compliance therewith and proper maintenance will result in an installation essentially free from hazard!

In all other areas of the world, equipment should be installed in accordance with the existing local codes. Please contact your local authorities.

Stationary appliances which are not equipped with a power cord and a plug or other device to disconnect the appliance from the power source must have an all-pole disconnecting device with a contact gap of at least 3 mm installed in the external installation.



CAUTION: THIS EQUIPMENT MUST BE PROPERLY GROUNDED! FAILURE TO DO SO CAN RESULT IN SEVERE PERSONAL INJURY FROM ELECTRICAL SHOCK!

Beater rotation must be clockwise as viewed looking into the freezing cylinder.

Note: The following procedures should be performed by a trained service technician.

To correct the rotation on a three-phase unit, interchange any two incoming power supply lines at freezer main terminal block only.

To correct rotation on a single-phase unit, change the leads inside the beater motor. (Follow the diagram printed on the motor.)

Electrical connections are made directly to the terminal block. The terminal block is provided in the main control box located behind the rear panel.



To the Operator

The freezer you have purchased has been carefully engineered and manufactured to give you dependable operation. The Taylor Models 770C and 771C, when properly operated and cared for, will produce a consistent quality product. Like all mechanical products, this machine will require cleaning and maintenance. A minimum amount of care and attention is necessary if the operating procedures outlined in this manual are followed closely.

This Operator's Manual should be read before operating or performing any maintenance on your equipment.

Your Taylor freezer will NOT eventually compensate for and correct any errors during the set-up or filling operations. Thus, the initial assembly and priming procedures are of extreme importance. It is strongly recommended that all personnel responsible for the equipment's operation study these procedures together in order to be properly trained and to make sure that no misunderstandings exist.

If you require technical assistance, please contact your local authorized Taylor Distributor.



If the crossed out wheeled bin symbol is affixed to this product, it signifies that this product is compliant with the EU Directive as well as other similar legislation in effect after August 13, 2005. Therefore, it must be collected separately after its use is completed, and cannot be disposed as unsorted municipal waste.

The user is responsible for returning the product to the appropriate collection facility, as specified by your local code.

For additional information regarding applicable local laws, please contact the municipal facility and/or local distributor.

COMPRESSOR WARRANTY DISCLAIMER

The refrigeration compressor(s) on this machine are warranted for the term indicated on the warranty card accompanying this machine. However, due to the Montreal Protocol and the U.S. Clean Air Act Amendments of 1990, many new refrigerants are being tested and developed, thus seeking their way into the service industry. Some of these new refrigerants are being advertised as drop-in replacements for numerous applications. It should be noted that, in the event of ordinary service to this machine's refrigeration system, **only the refrigerant specified on the affixed data label should be used.** The unauthorized use of alternate refrigerants will void your compressor warranty. It will be the owner's responsibility to make this fact known to any technician he employs.

It should also be noted that Taylor does not warrant the refrigerant used in its equipment. For example, if the refrigerant is lost during the course of ordinary service to this machine, Taylor has no obligation to either supply or provide its replacement either at billable or unbillable terms. Taylor does have the obligation to recommend a suitable replacement if the original refrigerant is banned, obsoleted, or no longer available during the five year warranty of the compressor.

The Taylor Company will continue to monitor the industry and test new alternates as they are being developed. Should a new alternate prove, through our testing, that it would be accepted as a drop-in replacement, then the above disclaimer would become null and void. To find out the current status of an alternate refrigerant as it relates to your compressor warranty, call the local Taylor Distributor or the Taylor Factory. Be prepared to provide the Model/Serial Number of the unit in question.



Data Plate

The freezer data plate provides necessary information that the operator should record and refer to when this information is requested by:

Two data plates are located on the rear panel for Model 771C and the front panel for Model 770C, requiring two separate electrical hook-ups, one for each refrigeration system.

- A. Electrician
- B. Service Technician
- C. Parts Manager for service parts
- D. Warranty status

TAYLOR
VALUES EACH

PART NUMBER: _____
 MODEL NUMBER: _____
 SERIAL NUMBER: _____

VOLTS _____ HZ _____ PH _____

	NO.	COOLING	HEATING	LRA/HP	REFRIGERANT
COMPRESSOR		RLA	RLA	LRA	OZ.
COMPRESSOR		RLA	RLA	LRA	OZ.
COMPRESSOR		RLA	RLA	LRA	OZ.
COMPRESSOR		FLA	FLA	HP	DESIGN PRESSURE - ALL CIRCUITS (PSIG) LOW: _____ HIGH: _____
COMPRESSOR		FLA	FLA	HP	
COMPRESSOR		FLA	FLA	HP	MAXIMUM FUSE SIZE OR CIRCUIT BREAKER _____ A. MINIMUM WIRE AMPACITY _____ A. TOTAL AMP _____
COMPRESSOR		FLA	FLA	HP	
COMPRESSOR		FLA	FLA	HP	UNITED STATES PATENT ONE OR MORE OF THE FOLLOWING 4201558 4364666 4509905 4283461 4390760 4732013 4275567 4393659 4878760 4364491 4544085 0256124 PROTECTED BY VARIOUS FOREIGN PATENTS—OTHER PATENTS PENDING
COMPRESSOR		FLA	FLA	HP	
COMPRESSOR		FLA	AMP	HP	
COMPRESSOR		FLA	AMP	HP	

TAYLOR COMPANY ROCKTON, ILLINOIS, U.S.A.
MADE IN U.S.A. 44324 REV

Complete for quick reference when this information is requested:

- 1. Model Number: _____
- 2. Serial Number: _____
- 3. Electrical Specs: Voltage _____ Cycle _____
Phase _____
- 4. Maximum Fuse Size: _____ Amps
- 5. Minimum Wire Ampacity: _____ Amps
- 6. Part Number: _____



Safety

We at Taylor Company are concerned about the safety of the operator when he or she comes in contact with the freezer and its parts. Taylor has gone to extreme efforts to design and manufacture built-in safety features to protect both you and the service technician. As an example, warning labels have been attached to the freezer to further point out safety precautions to the operator.



IMPORTANT - Failure to adhere to the following safety precautions may result in severe personal injury. Failure to comply with these warnings may also damage the machine and its components. Component damage will result in part replacement expense and service repair expense.

To Operate Safely:



DO NOT operate the freezer without reading this operator's manual. Failure to follow this instruction may result in equipment damage, poor freezer performance, health hazards, or personal injury.



- **DO NOT** operate the freezer unless it is properly grounded.
- **DO NOT** attempt any repairs unless the main power supply to the freezer has been disconnected.
- **DO NOT** operate the freezer with larger fuses than specified on the freezer data label.

Failure to follow these instructions may result in electrocution or damage to the machine. Contact your local authorized Taylor Distributor for service.



DO NOT use a water jet to clean or rinse the freezer. Failure to follow this instruction may result in serious electrical shock.



- **DO NOT** allow untrained personnel to operate this machine.
- **DO NOT** operate the freezer unless all service panels and access doors are restrained with screws.
- **DO NOT** remove the door, beater and blades, or drive shaft unless all control switches are in the OFF position.
- **DO NOT** put objects or fingers in door spout.

Failure to follow these instructions may result in contaminated product or severe personal injury to fingers or hands from hazardous moving parts.



USE EXTREME CAUTION when removing the beater assembly. The scraper blades are very sharp and may cause injury.



This freezer must be placed on a level surface. Failure to comply may result in personal injury or equipment damage.

DO NOT obstruct air intake and discharge openings:

Model 770C: A minimum of 6" (152 mm) air space is required on sides and rear, and 7-1/2" (191 mm) on the bottom.

Model 771C: A minimum of 3" (76 mm) air space is required on sides and rear, and 6-1/8" (156 mm) on the bottom.

Failure to follow these instructions may cause poor freezer performance and damage to the machine.

These freezers are designed to operate indoors, under normal ambient temperatures of 70°-75°F (21°-24°C). The freezers have successfully performed in high ambient temperatures of 104°F (40°C) at reduced capacities.

NOISE LEVEL: Airborne noise emission does not exceed 78 dB(A) when measured at a distance of 1.0 meter from the surface of the machine and at a height of 1.6 meters from the floor.



Taylor Company® Warranty

A warranty checkout card is shipped with every new freezer that leaves the factory. The warranty checkout card is packed in an envelope which also contains this operator's manual. Refer to the warranty checkout card and the warranty classifications listed in the parts list at the back of this manual when service is performed on your freezer.

It is strongly recommended that the operator take the necessary time to carefully read through the complete warranty information contained in the warranty checkout card. Any questions or unclear statements found within the card should be made clear to you upon delivery of the freezer. Thoroughly understand your warranty protection before you begin operation.

Taylor Company stands behind the quality of design and manufacturing that is put into every model we make...more so than anyone else in the industry. The Taylor Company Warranty is a strong example of this and exemplifies how important we feel it is to keep you a satisfied and proud owner of a Taylor freezer.

For any questions pertaining to the Taylor Warranty, please contact your authorized Taylor Distributor or Taylor Company, Rockton, Illinois 61072.



Controls and Panels

Model 771C

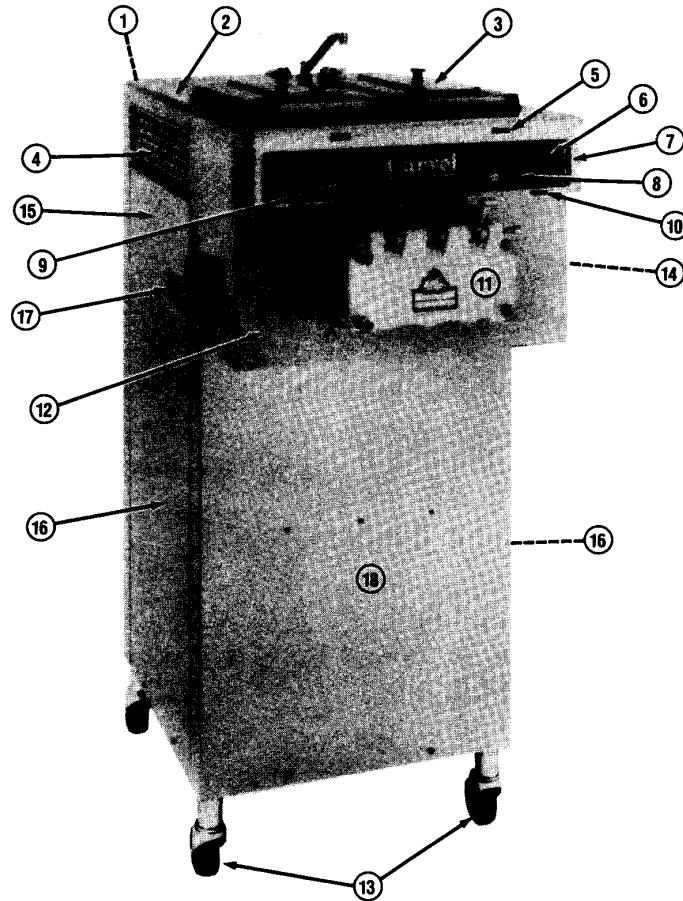

Item	Description	Part No.	Item	Description	Part No.
1.	Rear Panel	044160	10.	Temperature Control Knob*	013731
2.	Hood	044162	11.	Freezer Door Assembly	X44163
3.	Mix Hopper Cover Assembly	X38458	12.	Front Upper Panel Assembly	X44133
4.	Side Louver	017471	13.	Swivel Caster	018794
5.	Indicator Light "Mix Low"**	023056-	14.	Right Upper Side Panel	044131
6.	Decorative Decal	044576	15.	Left Upper Side Panel	044130
7.	Decorative Plate	044137	16.	Lower Side Panel Assembly	X44138
8.	Dial Light*	014118	17.	Rear Drip Pan	027503
9.	Control Switch "Wash-Off-Auto"*	014237	18.	Lower Front Panel	044161

*See page 14 for more detailed information.



Controls and Panels

Model 770C

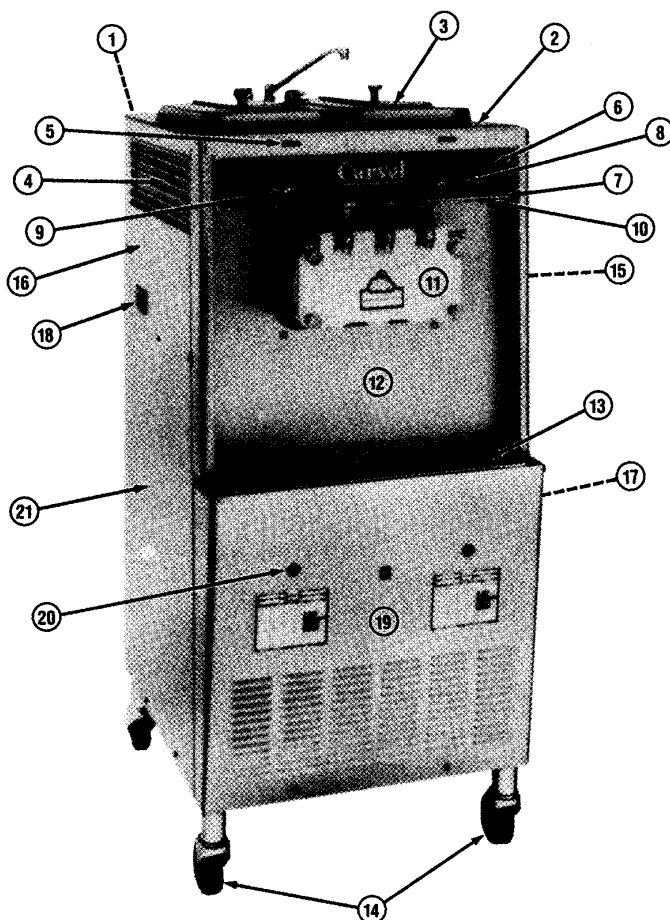

Item	Description	Part No.	Item	Description	Part No.
1.	Rear Panel	017563	11.	Freezer Door Assembly	X44163
2.	Hood	044466	12.	Front Panel Assembly	X15575
3.	Mix Hopper Cover Assembly	X38458	13.	Splash Shield	022766
4.	Side Louver	017471	14.	Swivel Caster	018794
5.	Indicator Light "Mix Low"*	023056-	15.	Right Upper Side Panel	028701
6.	Decorative Decal	044576	16.	Left Upper Side Panel	028700
7.	Switch Cover	022614	17.	Lower Right Side Panel Assembly	X44855
8.	Dial Light*	014118	18.	Rear Drip Pan	027503
9.	Control Switch "Wash-Off-Auto"*	014237	19.	Service Panel	024439
10.	Temperature Control Knob*	013731	20.	Reset Button (Beater Line Starter)*	014164-
			21.	Lower Left Side Panel Assembly	X44853

*See page 14 for more detailed information.



Specifications

Model 771C

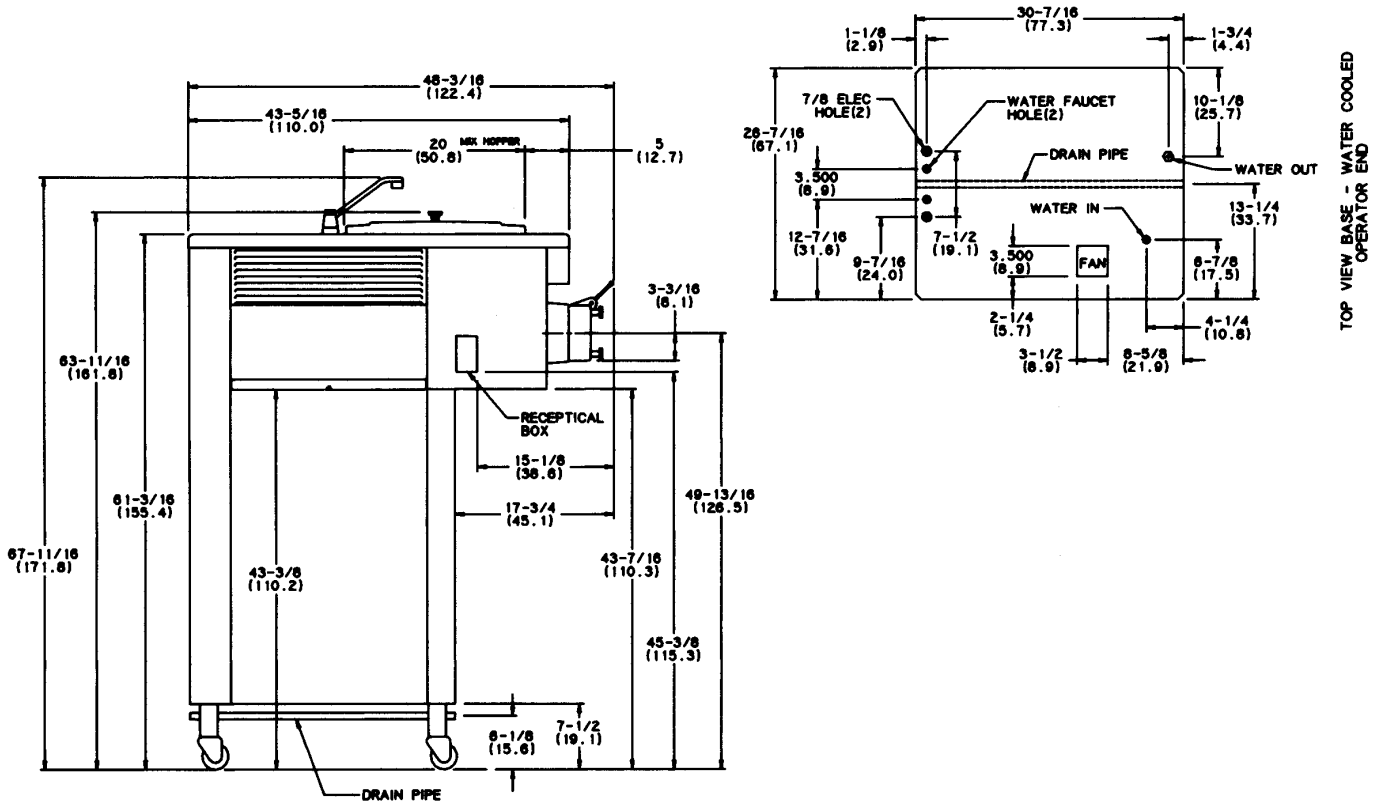

(Figures in parentheses indicate centimeters.)

- **FREEZING CYLINDER.** Two; 7 quart (6.6 liter) capacity.
- **MIX HOPPER.** Two; 20 quart (18.9 liter) capacity.
- **BEATER MOTOR.** Two; 3.0 hp.
- **REFRIGERATION UNIT.** Two; approximately 13,000 btu/hr compressor. Refrigerant 502.
- **ELECTRICAL.** Standard is 115/208-230-60-3. Each unit requires electrical service* — Three Phase Maximum Fuse Size: 45 Amps Left, 45 Amps Right. Minimum Circuit Ampacity: 37A Left, 37A Right.
- **WATER COOLED.** Water inlet and drain connections under side of base 1/2" FPT. Air Clearance: 3" (7.6 cm.) around all sides.
- **DIMENSIONS.** Width: 26-7/16" (67.2 cm.). Depth: 48-3/16" (122.4 cm.). Height: 67-11/16" (171.9 cm.). Floor Clearance: 6-1/8" (15.6 cm.) mounted on standard casters.
- **APPROXIMATE WEIGHTS.** Net: 835 lbs. (378.8 kgs.). Crated: 985 lbs. (446.8 kgs.), 69.3 cu. ft. (2.0 cu. m.).

*For exact electrical information, always refer to the data plate of the unit.

Availability and specifications subject to change without notice.



Specifications

Model 770C

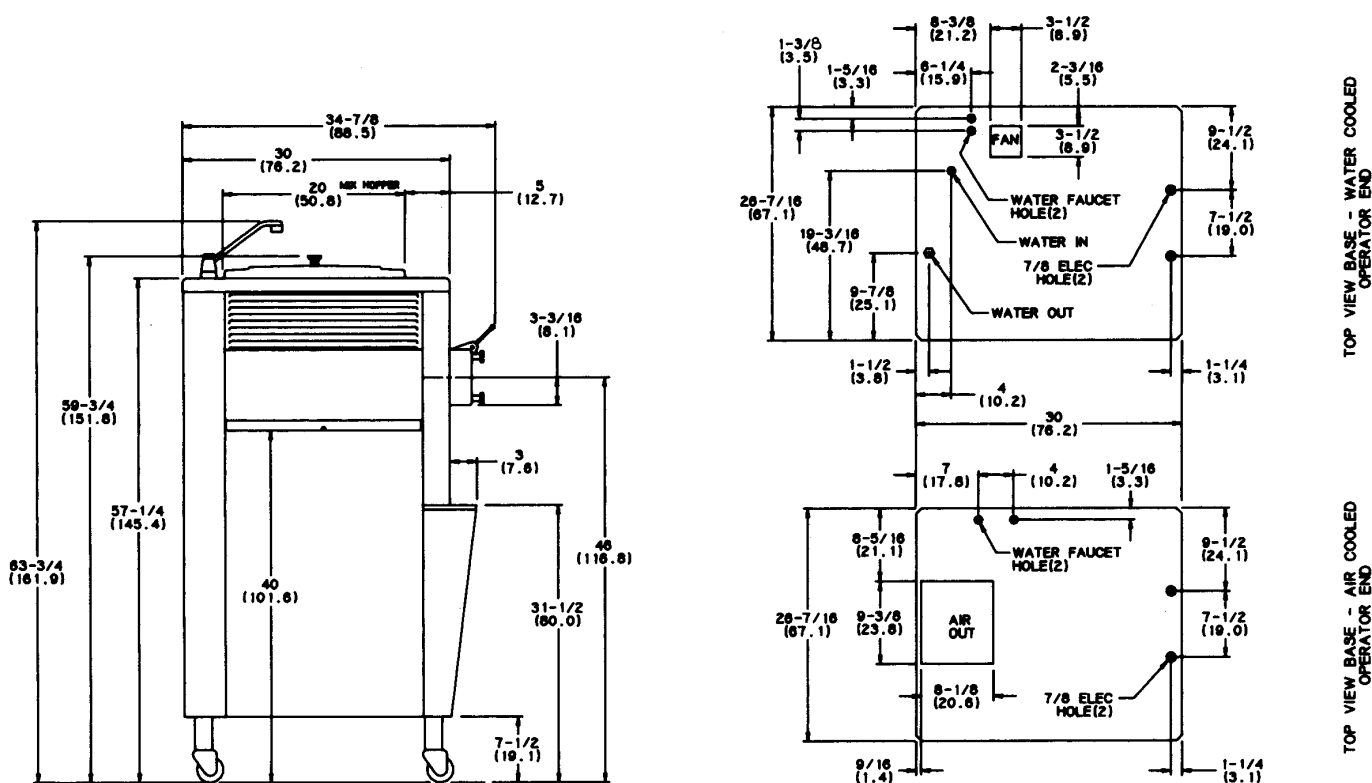

(Figures in parentheses indicate centimeters.)

- **FREEZING CYLINDER.** Two; 7 quart (6.6 liter) capacity.
- **MIX HOPPER.** Two; 20 quart (18.9 liter) capacity.
- **BEATER MOTOR.** Two; 3.0 hp.
- **REFRIGERATION UNIT.** Two; approximately 9,800 btu/hr compressor. Hi Capacity: Two; approximately 13,000 btu/hr compressor. Refrigerant 502.
- **ELECTRICAL.** Standard is 208-230-60-3. Each unit requires electrical service* — Three Phase Maximum Fuse Size: 30 Amps Left, 25 Amps Right. Minimum Circuit Ampacity: 24A Left, 20A Right. Hi Capacity Three Phase Maximum Fuse Size: 30 Amps Left, 30 Amps Right. Minimum Circuit Ampacity: 22A Left, 22A Right.
- **AIR COOLED.** Clearance 6" (15.2 cm.) around all sides.
- **WATER COOLED.** Water inlet and drain connections under side of base 1/2" FPT. Air Clearance: 6" (15.2 cm.) around all sides.
- **DIMENSIONS.** Width: 26-7/16" (67.2 cm.). Depth: 34-7/8" (88.6 cm.). Height: 63-3/4" (161.9 cm.). Floor Clearance: 7-1/2" (19.1 cm.) mounted on standard casters.
- **APPROXIMATE WEIGHTS.** Net: 776 lbs. (352.0 kgs.). Crated: 856 lbs. (388.3 kgs.), 48.1 cu. ft. (1.3 cu. m.).

*For exact electrical information, always refer to the data plate of the unit.

Availability and specifications subject to change without notice.



Operator Parts Identification

ITEM	DESCRIPTION	FUNCTION
1	Beater Assembly	Turns inside freezing cylinder to blend air and mix and eject product. The beater should turn clockwise when observed from the operator's end. Drives scraper blades.
2	Scraper Blades	To scrape frozen product off inside wall of freezing cylinder. Must be sharp.
3	Drive Shaft	Connecting part from gear unit to beater. Shaft must be properly lubricated.
4	Seal (Drive Shaft)	Provides seal from product inside cylinder to external areas of freezer. Must be properly lubricated.

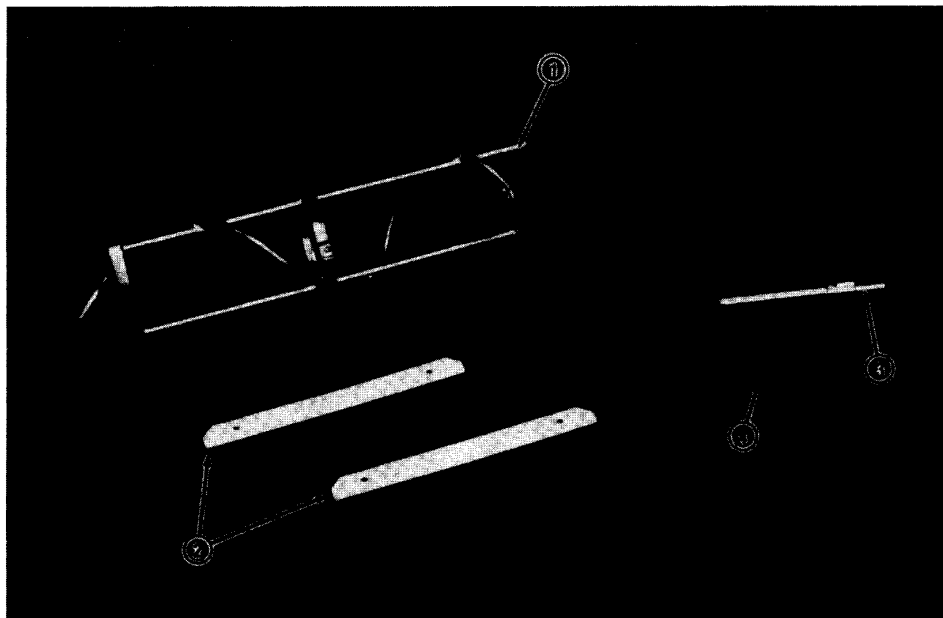

ITEM	DESCRIPTION	FUNCTION
5	Freezer Door Assembly	Covers the open end of the freezing cylinder and provides a port for frozen mix to be ejected.
6	O-Ring (Freezer Door)	Provides a seal between the freezer door and the freezing cylinder. Must be properly lubricated.
7	Front Bearing (Freezer Door)	Allows beater to turn freely on hub of freezer door. Do not lubricate.
8	Draw Valve	Seals off mix port in freezer door. Opens port when raised allowing frozen mix to be ejected.
9	O-Ring (Draw Valve)	Provides seal for draw valve in freezer door. Must be lubricated properly.
10	Adjustable Draw Handle	Raises or lowers the draw valve to eject or stop the flow of product from the freezing cylinder.
11	Pivot Pin	Allows a pivoting point for the draw handle to raise and lower the draw valve.
12	O-Ring (Pivot Pin)	Prevents pivot pin from slipping. Must be lubricated properly.
13	Handscrew	Tightening mechanism to secure door to freezing cylinder. Tighten equally.
14	Design Cap	Provides star design for product being ejected.
15	Inner Air Tube Assembly	Regulates the amount of air and mix into the freezing cylinder when used in conjunction with the outer air tube.
16	Outer Air Tube Assembly	Regulates the amount of air and mix into the freezing cylinder when used in conjunction with the inner air tube.

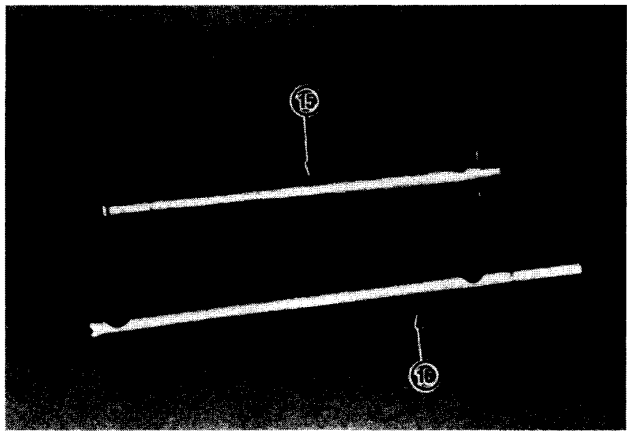
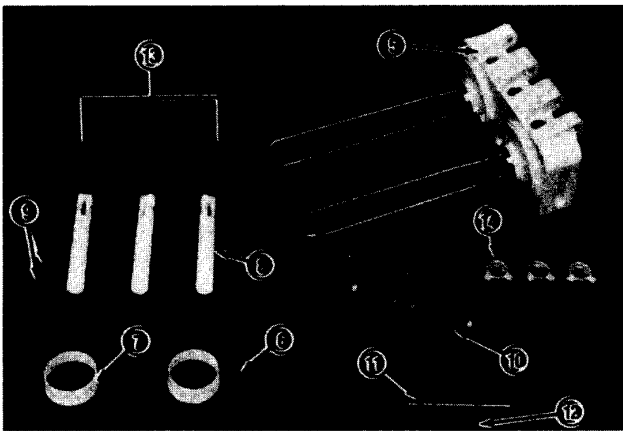



Accessories

ITEM	DESCRIPTION	FUNCTION
17	Pail (10 quart - 9.5 liter)	Used for cleaning and sanitizing freezer.
18	Tune-Up Kit Assembly	Kit that contains replacement parts for all wear items.
19	Kay-5 Sanitizer	Approved 100 PPM cleaning and sanitizing solution.
20	Rear Drip Pan	Used to collect any mix leakage from the rear shell bearing.
21	Taylor Lube (Petro Gel may be used as an alternative.)	Approved lubricant for moving parts and wear items. Follow lubricating procedures in "Assembly" portion of Operating Procedures.
22	Spout Adaptor	Attaches to the end of the door spout for ease in filling cake molds and tubs.
23	Mix Hopper Cover Assembly	Protects mix in mix hopper from any debris dropping in.
24	Mix Hopper Gasket	Provides a seal between mix hopper and mix hopper cover.
25	Splash Shield (not shown)	Helps to prevent any mix leakage from door spout from splashing out.
26	Drip Tray (not shown)	Catches any excessive mix leakage from door spout.
27	White Bristle Brush, 3" x 7"	Use: Mix hopper.
28	White Bristle Brush, 1" x 2"	Use: Freezer door, draw valve port.
29	Black Bristle Brush, 1" x 2"	Use: Rear shell bearing.
30	Double-Ended Brush	Use: Freezer door port holes and all o-ring grooves.

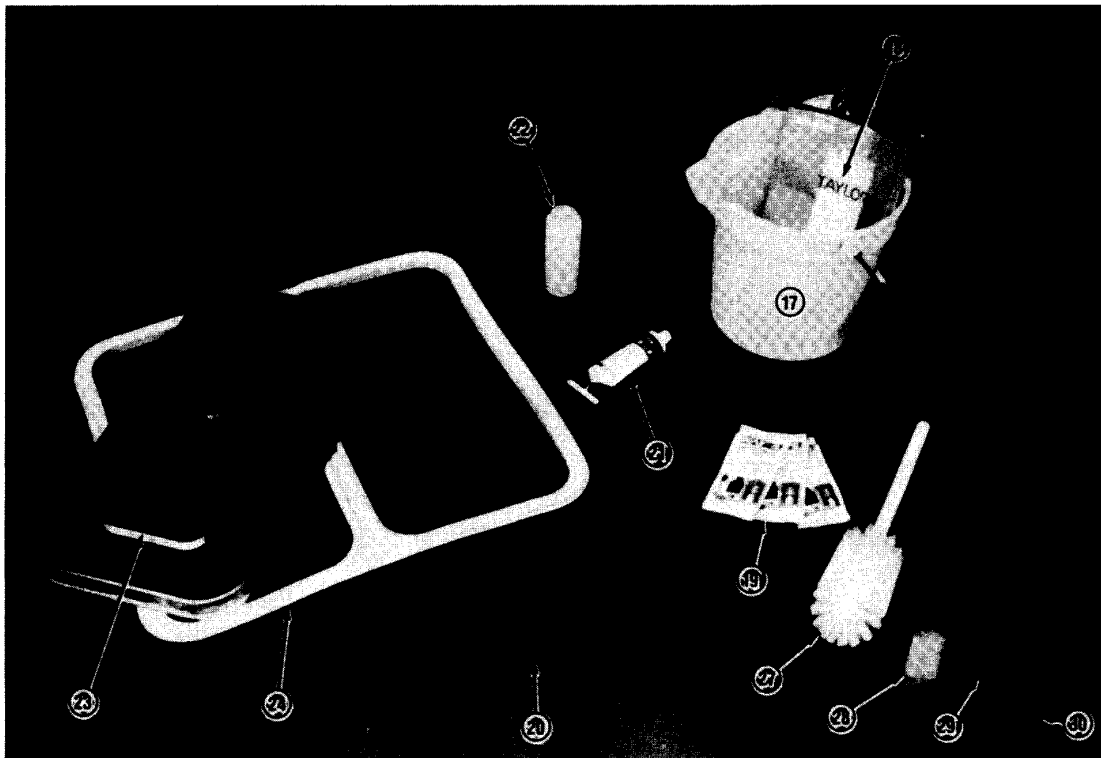

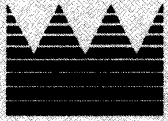

Important: To the Operator

CONTROL SWITCH

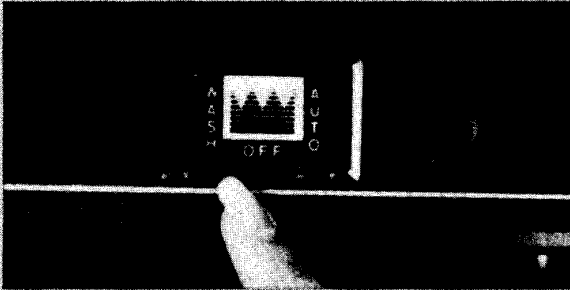

The center position is "OFF." The left position is "WASH," which activates the beater motor only. The right position is "AUTO," which activates the beater motor and refrigeration system to freeze down and maintain the product in the freezing cylinder.

DIAL LIGHT

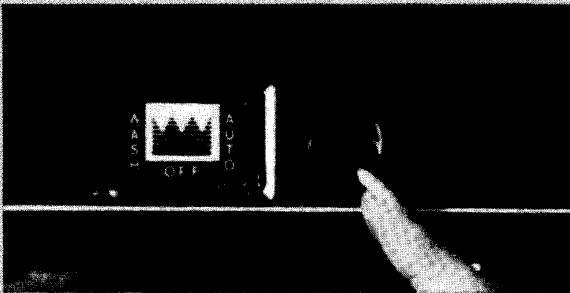

Located on the right side of the control switch is a red dial light. When the control switch is in the "AUTO" position, this light will come on, indicating the refrigeration system is operable.

INDICATOR LIGHT "MIX LOW"



This unit is equipped with a "MIX LOW" light located on the front of the machine. When the light begins to flash, it indicates that the mix hopper has a low supply of mix. At this time, the hopper should be filled with mix. Should you neglect to add mix when the light begins to flash, eventual damage to the beater, blades, drive shaft, and freezer door, may occur.

RESET MECHANISM

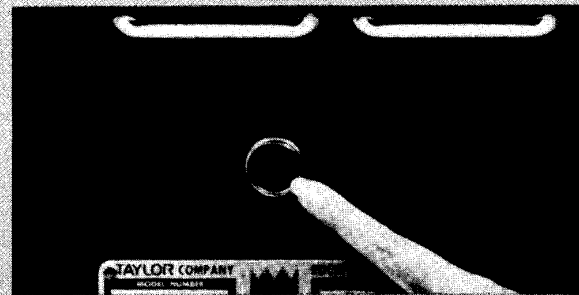

There are two reset buttons, located in the rear panel on the Model 771C and in the service panel on the Model 770C, one for each side of the freezer. The reset mechanism protects the beater motor from an overload condition. Should an overload occur, the reset mechanism will trip. To properly reset the freezer, place the control switch in the "OFF" position. Depress the reset button firmly. Place the control switch in the "WASH" position and observe the freezer's performance. Return the control switch to the "AUTO" position.

If the reset mechanism should trip again, contact your authorized Taylor distributor to resolve the problem of the beater motor going out on reset.

CIRCUIT BREAKER



The electrical receptacles on the sides of the freezer are protected by circuit breakers. The white reset buttons for the circuit breakers are located in the rear panel, adjacent to the beater motor reset buttons.

TEMPERATURE CONTROL



The product temperature is adjusted by means of a temperature control. Located under the control channel is the temperature control adjustment knob. Turning the adjustment knob clockwise will decrease product temperature and counterclockwise will increase the temperature. Each quarter turn will vary the temperature approximately 1° F (.55° C). Allow the refrigeration system to cycle on and off two or three times before the adjusted temperature can be evaluated.

ADJUSTABLE DRAW HANDLE

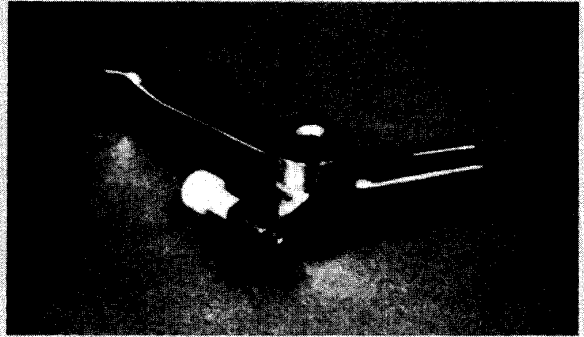

These units feature an adjustable draw handle to provide the best portion control, giving a better consistency quality to your product, and controlling costs. The draw handle should be adjusted to provide a flow rate of 5 to 7-1/2 oz. of product by weight per 10 seconds. To INCREASE the flow rate, turn the screw COUNTERCLOCKWISE and CLOCKWISE to DECREASE the flow rate. In addition, for purposes of "Sanitizing" and "Rinsing," the flow rate can be increased by removing the pivot pin and placing the restrictive bar on the TOP. When drawing product, **always** have the restrictive bar on the BOTTOM.



Operating Procedures

The Model 771C has been selected to show you the pictured step-by-step operating procedures for both Models 770C and 771C contained in this manual. These models, for all practical purposes of operation, are the same.

Each unit stores mix in a hopper. The mix flows **by gravity** from the hopper down into the freezing cylinder through an air tube. They both have two 20 quart (18.9 liter) mix hoppers and two 7 quart (6.6 liter) freezing cylinders.

We begin our instructions at the point where we enter the store in the morning and find the parts disassembled and laid out to air dry from the previous night's cleaning.

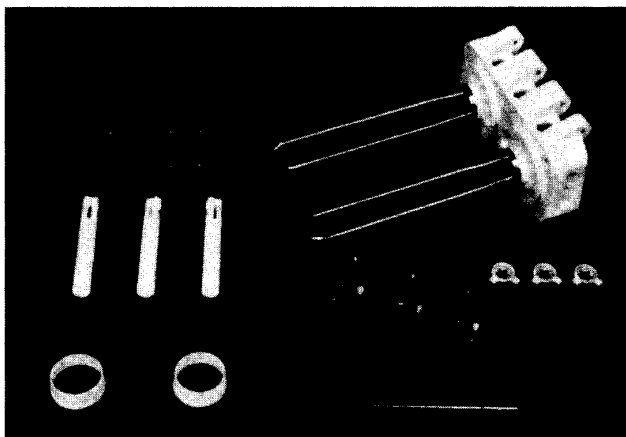
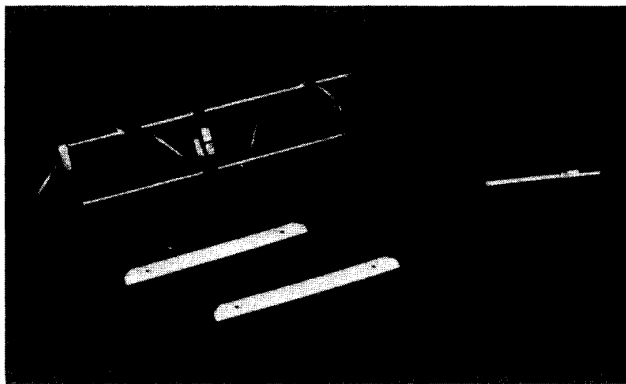

The following procedures will show you how to assemble the parts into the freezer, sanitize them, and prime the freezer with fresh mix in preparation to serve your first product.

If you are disassembling the machine for the first time or need information to get to this starting point in our instructions, turn to page 22, "Disassembly," and start there.

ASSEMBLY

MAKE SURE THE CONTROL SWITCHES ARE IN THE "OFF" POSITION.

NOTE: When lubricating parts, use an approved food grade lubricant (Example: Taylor Lube or Petro Gel).

Step 1

Install drive shaft. Lubricate the groove and shaft portion that come in contact with the bearing on the beater drive shaft. Slide the seal over the shaft and groove until they snap into place. **DO NOT** lubricate the hex end of the drive shaft. Fill the inside portion of the seal with 1/4" more lubricant and evenly lubricate the flat side of the seal that comes in contact with the bearing.

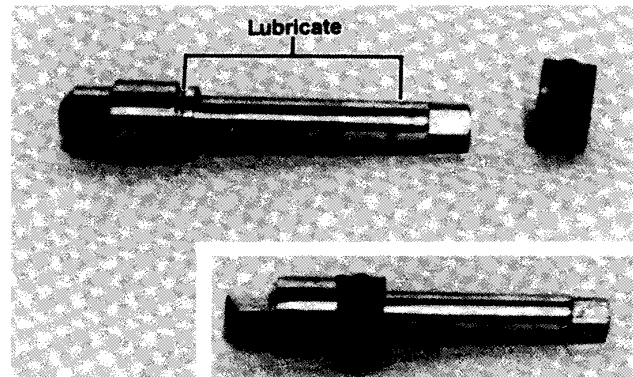

Insert the drive shaft through the rear shell bearing in the freezing cylinder and engage the hex end firmly into the gear box coupling.

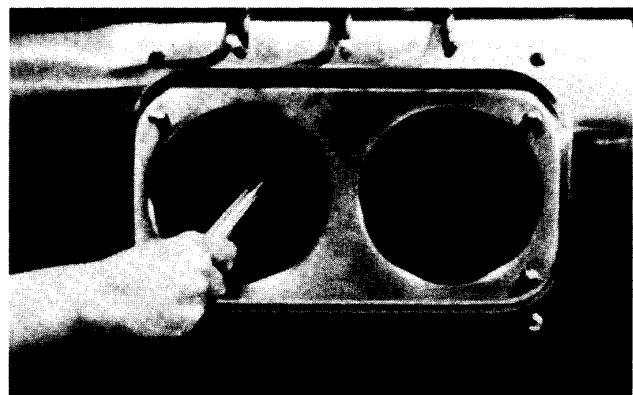

Step 2

Install beater assembly. First check scraper blades for any nicks or signs of wear (minimum width 15/16" [2.4 cm]). If any nicks are present or if the width is less than 15/16" (2.4 cm), replace blades.

NOTE: To prevent costly damage, both holes on the scraper blade must fit securely over both pins.

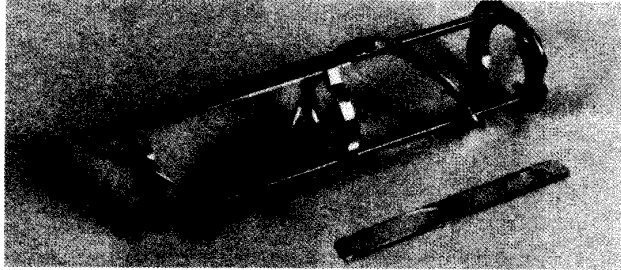

If blades are in good condition, place the rear scraper blade over the two rear holding pins on the beater, knife edge to the outside. Holding the rear blade on the beater, slide into the freezing cylinder halfway, tail end first. Install front scraper blade over the two front holding pins. Slide the beater assembly the rest of the way into the freezing cylinder.

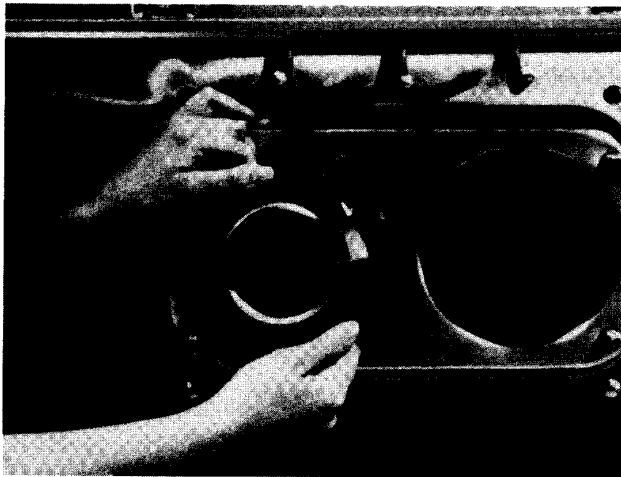

CAUTION: The scraper blades are very sharp and could cut unless properly handled.

Make sure beater assembly is in position over the drive shaft. Turn the beater slightly to be certain that the beater is properly seated. When in position, the beater will be approximately 1/2" inside the front of the freezing cylinder. **Important:** Failure to properly seat the beater may cause damage to the beater and/or door.

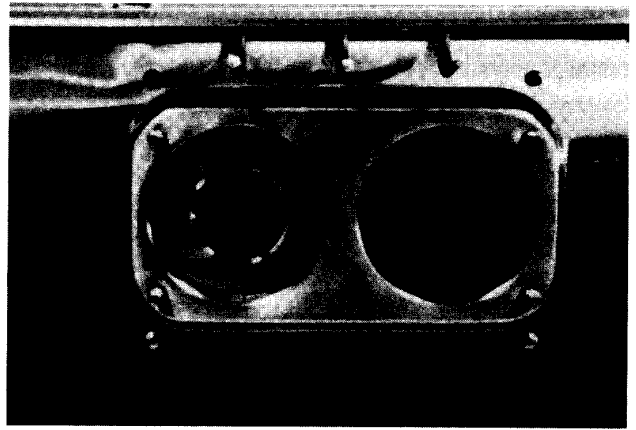

Repeat Steps 1 and 2 for the second freezing cylinder.

Step 3

Assemble freezer door. Place the large o-rings into the grooves on the back of the freezer door and lubricate.

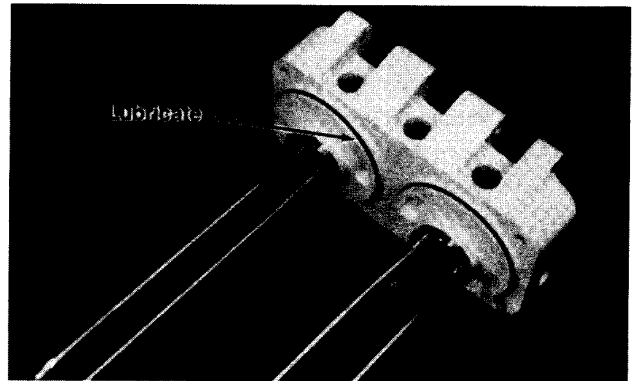

Slide the white plastic front bearings over the baffle rods onto the bearing hubs making certain that the flanged end of the bearing is resting against the freezer door. **DO NOT LUBRICATE THE FRONT BEARING.**

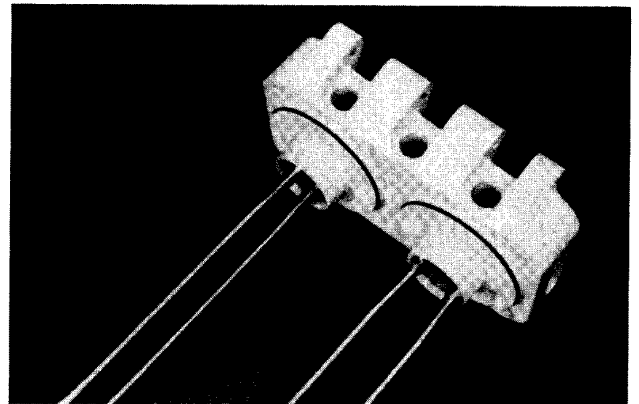

Step 4

Install freezer door. Insert the baffle rods through the opening in the beaters and seat the door flush with the freezing cylinder. With the door seated on the freezer studs, install the handscrews. Tighten equally in a criss-cross pattern to insure the door is snug.

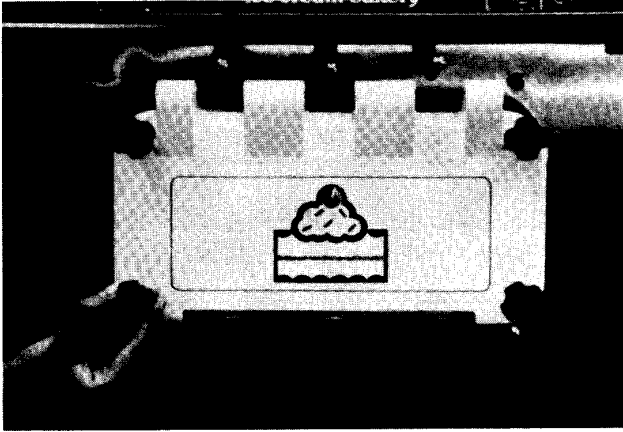

Step 5

Install the draw valves. Slide the two o-rings into the grooves on the draw valves and lubricate.

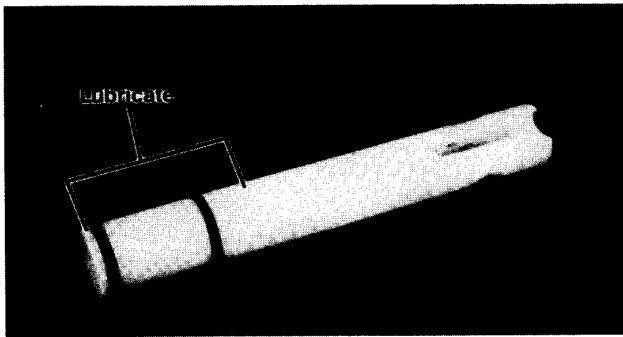

Lubricate the inside of the freezer door spouts, top and bottom and insert the draw valves from the **bottom** until the slot in the draw valves comes into view.

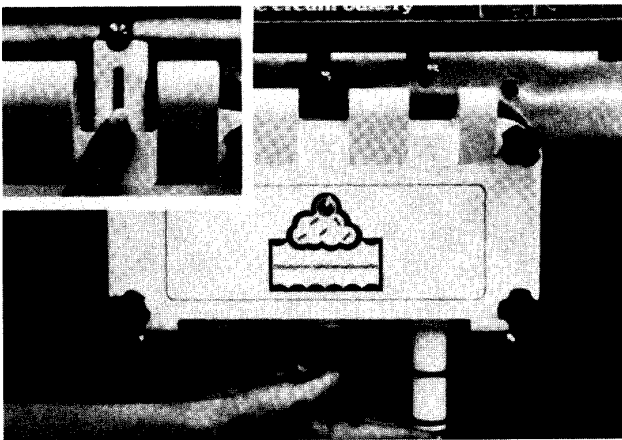

Step 6

Install adjustable draw handles. Slide the o-ring into the groove on the pivot pin and lubricate.

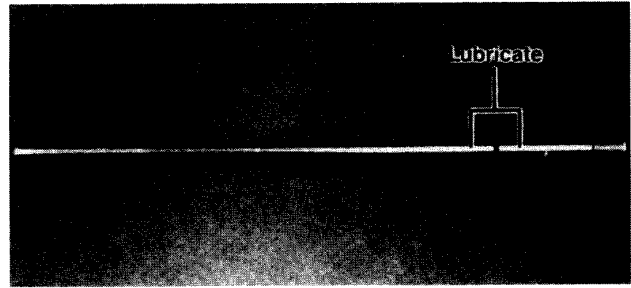

Slide the fork of the draw handle in the slot of the draw valve, starting from the right. Slide the pivot pin through each draw handle as you insert them into the draw valves.

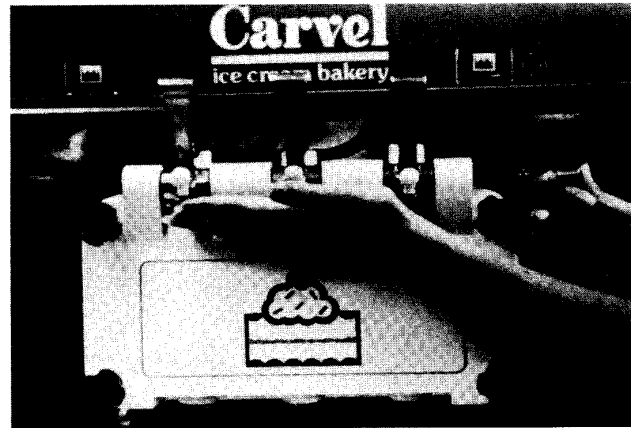

NOTE: These units feature adjustable draw handles to provide the best portion control, giving a better consistency quality to your product, and controlling costs. The draw handles can be adjusted for different flow rates. See page 15 for more information on adjusting these handles.

Step 7

Snap the design caps over the end of each door spout.

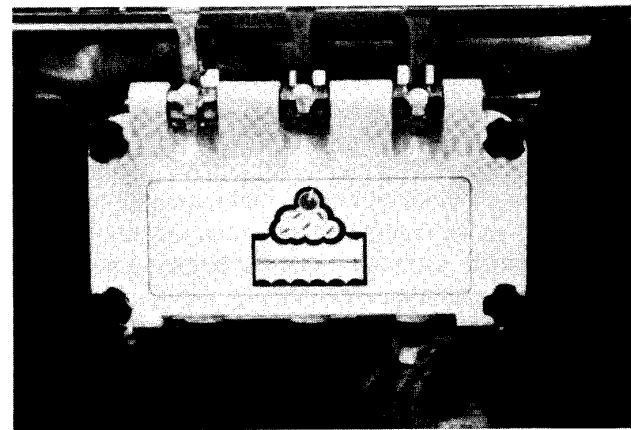

Step 8

Lay the inner and outer air tubes and hopper gasket in the bottom of the mix hopper.

NOTE: There is only one hopper gasket for both mix hoppers.

Step 9

Slide the rear drip pan into the hole in the side panel.

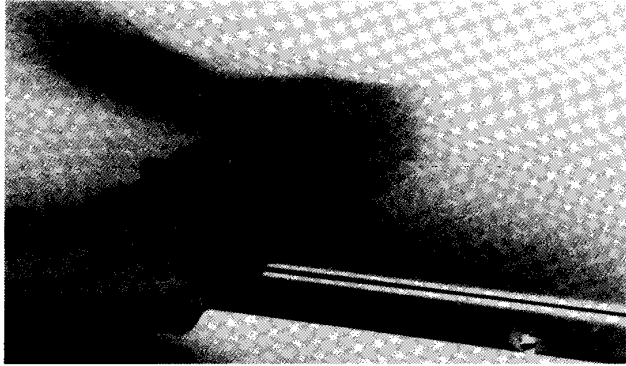

Repeat Steps 8 and 9 for the other side of the freezer.

Step 10

Model 770C: Install the front drip tray and splash shield under the door spouts.

SANITIZING

Step 1

Prepare 7-1/2 gallons (28.4 liters) of an approved 100 PPM sanitizing solution (Example: Kay-5 or Carvel Dual Chlor) with WARM WATER ACCORDING TO THE MANUFACTURER'S SPECIFICATIONS.

Step 2

Pour half of the sanitizing solution into the hopper and allow it to flow into the freezing cylinder.



Step 3

While the solution is flowing into the freezing cylinder, brush clean the hopper. In cleaning the mix hopper, take particular care in brushing the mix level sensing probe on the rear wall of the hopper, the mix inlet hole, the inner and outer air tubes and the hopper gasket.



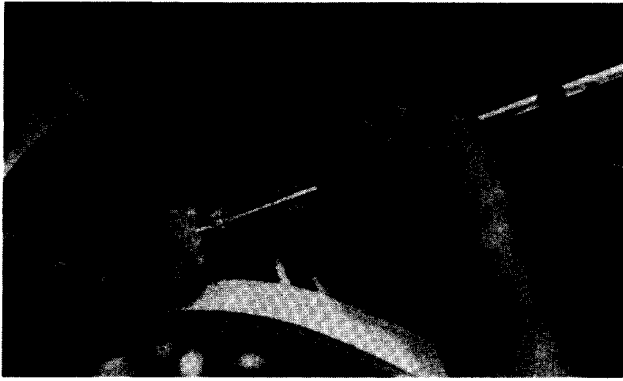

Step 4

Place the control switch in the "WASH" position. This will cause the sanitizing solution in the freezing cylinder to be agitated. Allow to agitate for five minutes.

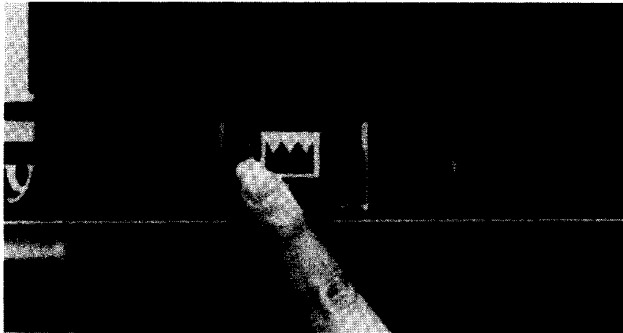

Step 5

Model 771C: Place three empty pails in the washer sink. Place the washer sink below the door spouts. Lower the draw handle and draw off all of the sanitizing solution.

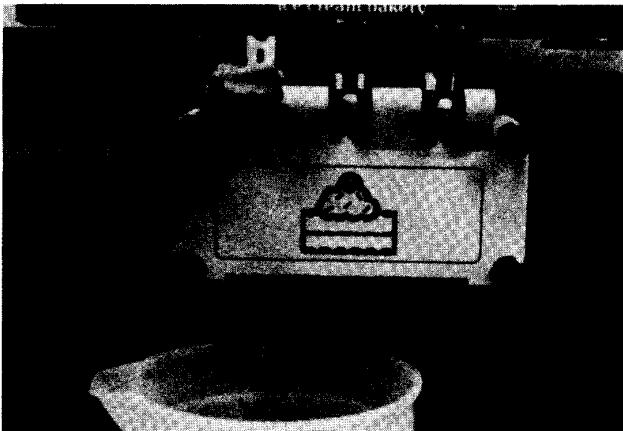

Model 770C: With a pail beneath the door spouts, lower the draw handle and draw off all of the sanitizing solution.

NOTE: Momentarily lower the center draw handle to sanitize the center door spout.

Step 6

When the sanitizer stops flowing from the door spout, raise the draw handle and place the control switch in the "OFF" position.

NOTE: You have just sanitized the freezer; therefore, **be sure your hands are sanitized** before going on in these instructions.

Step 7

Assemble the hopper gasket around the top edge of the mix hopper. Place inner air tube inside the outer air tube and stand in the corner of the mix hopper.



Repeat Steps 2 through 7 for the other side of the freezer.

PRIMING

Prime the machine as close to the time of first product draw as possible.

Step 1

Model 771C: With the washer sink beneath the door spouts, lower the draw handle.

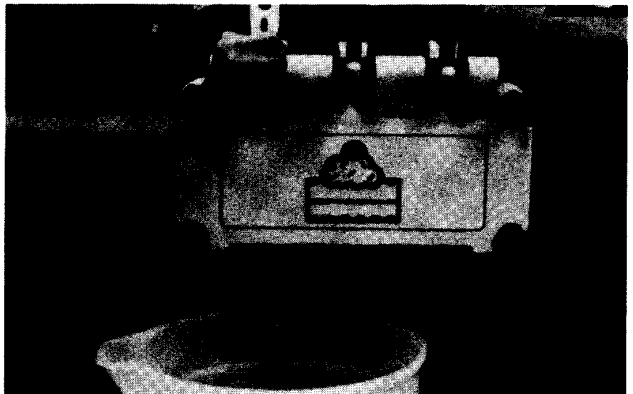

Model 770C: With a pail beneath the door spouts, lower the draw handle.

Pour two gallons (7.6 liters) of **FRESH** mix into the hopper and allow it to flow down into the freezing cylinder. This will force out any remaining sanitizing solution. When full strength mix is flowing from the door spout, raise the draw handle.

Step 2

When the mix has stopped bubbling down into the freezing cylinder, install the assembled air tube into the mix inlet hole in the mix hopper. Set the air tube assembly for the correct hole size according to the product being used.



Step 3

Place the control switch in the "AUTO" position. When the unit cycles off, the product will be at serving temperature.

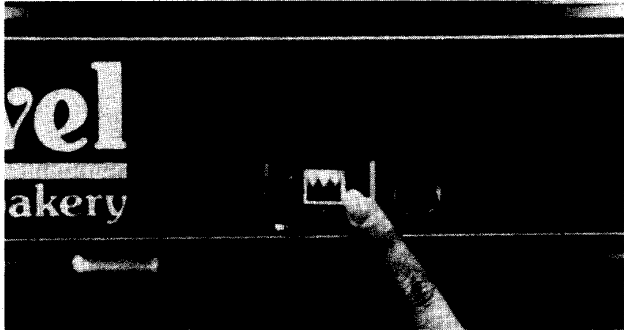

Step 4

Fill the hopper with mix. As the mix level comes in contact with the mix level sensing probe on the rear wall of the hopper, the "MIX LOW" light will shut off.

Step 5

Place the mix hopper cover in position.

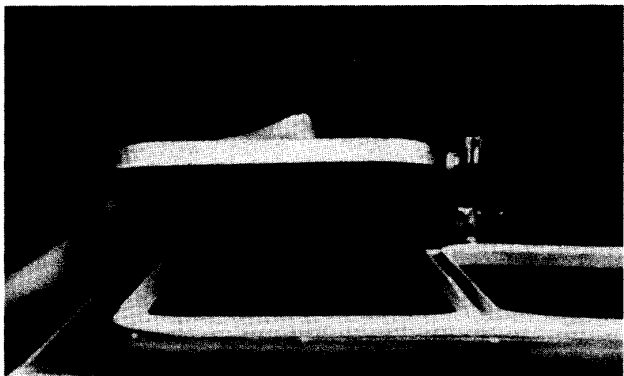

Repeat Steps 1 through 5 for the other side of the freezer.

CLOSING PROCEDURES

To disassemble the Models 771C and 770C, the following items will be needed:

- Three cleaning pails
- Necessary brushes provided with freezer
- Cleaner
- Single service towels

DRAINING PRODUCT FROM THE FREEZING CYLINDER

Step 1

Place the control switch in the "OFF" position.

Step 2

Remove the hopper cover, gasket, and assembled air tube, and take to the sink for cleaning.

Step 3

With a sanitized pail under the door spout, place the control switch in the "WASH" position and lower the draw handle. When all the product stops flowing from the door spout, raise the draw handle and place the control switch in the "OFF" position.

Repeat Steps 1 through 3 for the other side of the freezer.

RINSING

Step 1

Turn the faucet on, and fill the mix hopper 1/2 full with **cool** water. With the brushes provided, scrub the mix hopper, mix inlet hole, and mix level sensing probe.

Step 2

Place the control switch in the "WASH" position.

Step 3

Model 771C: Place the washer sink below the door spouts.

Model 770C: Place a pail beneath the door spouts.

Lower the draw handle and drain all the rinse water from the freezing cylinder. When the rinse water stops flowing from the door spout, raise the draw handle and place the control switch in the "OFF" position.

Repeat this procedure until the rinse water being drawn from the freezing cylinder is **clear**.

Repeat Steps 1 through 3 using **warm** water.

Repeat Steps 1 through 3 for the other side of the freezer.

CLEANING

Step 1

Prepare two gallons (7.6 liters) of an approved cleaning solution (Example: Kay-5 or Carvel Cleanser) with WARM WATER ACCORDING TO THE MANUFACTURER'S SPECIFICATIONS.

Step 2

Pour the two gallons (7.6 liters) of cleaning solution into the hopper and allow it to flow into the freezing cylinder.

Step 3

While the solution is flowing into the freezing cylinder, brush clean the mix hopper, mix inlet hole, and mix level sensing probe.

Step 4

Put the control switch in the "WASH" position. This will cause the cleaning solution in the freezing cylinder to be agitated.

Step 5

Model 771C: Place the washer sink beneath the door spout and lower the draw handle.

Model 770C: Place a pail beneath the door spout and lower the draw handle.

Draw off all the cleaning solution. When the solution stops flowing from the door spout, raise the draw handle and place the control switch in the "OFF" position.

Step 6

Turn the faucet on, and fill the hoppers 1/2 full with hot water. Place the control switch in the "WASH" position. Lower the draw handle and drain all the rinse water from the freezing cylinder and mix hopper.

Repeat Steps 1 through 6 for the other side of the freezer.

DISASSEMBLY

NOTE: Failure to remove parts, brush-clean and then air dry these parts, will result in damage to the related parts.

Step 1

BE SURE THE CONTROL SWITCHES ARE IN THE "OFF" POSITION.

Step 2

Remove the handscrews, freezer door, beater assemblies and scraper blades, and drive shafts from the freezing cylinders and take to the sink for cleaning.

NOTE: Take caution when removing door; the door may be heavier than what it appears.

BRUSH CLEANING

Step 1

Prepare a sink with an approved cleaning solution in WARM WATER ACCORDING TO THE MANUFACTURER'S SPECIFICATIONS.

If an approved cleaner other than Kay-5 is used, dilute according to label instructions. (**IMPORTANT:** Follow label directions, as too STRONG of a solution can cause parts damage, while too MILD of a solution will not provide adequate cleaning.) Make sure all brushes provided with the freezer are available for brush cleaning.

Step 2

Remove the seals from the drive shafts.

Step 3

From the freezer door remove:

1. gaskets
2. front bearings
3. design caps
4. draw valves

Remove all o-rings.

NOTE: To remove o-rings, use a single service towel to grasp the o-ring. Apply pressure in an upward direction until the o-ring pops out of its groove. With the other hand, push the top of the o-ring forward, and it will roll out of the groove and can be easily removed. If there is more than one o-ring to be removed, always remove the rear o-ring first. This will allow the o-ring to slide over the forward rings without falling into the open grooves.

Step 4

Return to the freezer with a small amount of cleaning solution. With the black bristle brush, brush-clean the rear shell bearings at the back of the freezing cylinders.

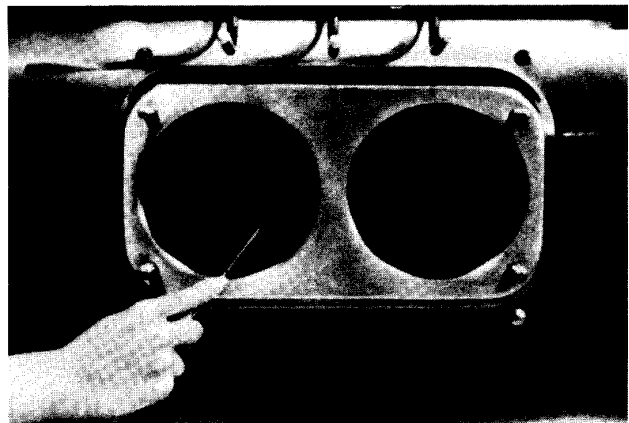

Step 5

Remove the rear drip pans from the side panels and take to the sink for cleaning.

NOTE: If the drip pan(s) is filled with an excessive amount of mix, it is an indication that the drive shaft seal should be replaced or was improperly lubricated.

Step 6

Thoroughly brush-clean all disassembled parts in the cleaning solution, making sure all lubricant and mix film is removed. Take particular care to brush-clean the draw valve holes in the freezer door. Place all the cleaned parts on a clean dry surface to air dry overnight.

Step 7

Wipe clean all exterior surfaces of the freezer.



Important: Operator Checklist

DURING CLEANING AND SANITIZING:

Cleaning and sanitizing schedules are governed by your State or local regulatory agencies and must be followed accordingly. The following check points should be stressed during the cleaning and sanitizing operations. **WE RECOMMEND DAILY CLEANING AND SANITIZING.**

ALWAYS FOLLOW LOCAL HEALTH CODES.

TROUBLESHOOTING BACTERIA COUNT:

- 1. Thoroughly clean and sanitize machine daily, including complete disassembly and brush cleaning.
- 2. Use all brushes supplied for thorough cleaning. The brushes are specially designed to reach all mix passageways.
- 3. Use the white bristle brush to clean the mix inlet hole which extends from the mix hopper down to the rear of the freezing cylinder.
- 4. Use the black bristle brush to thoroughly clean the rear shell bearing located at the rear of the freezing cylinder. Be sure to have a generous amount of cleaning solution on the brush.
- 5. Properly prepare the cleaning and sanitizing solutions. Read and follow label directions carefully. Too strong of a solution may damage the parts and too weak of a solution will not do an adequate job of cleaning or sanitizing.
- 6. Temperature of mix in mix hopper or walk-in cooler should be below 40° F (4.4° C).

REGULAR MAINTENANCE CHECKS:

- 1. Rotate scraper blades to allow both sides of the knife edge to wear evenly. This will contribute to self-sharpening and help maintain fast efficient freezing.
- 2. Replace scraper blades that are bent, damaged, or worn down to a width of 15/16" (2.4 cm) or less.
- 3. Before installing beater, be certain that scraper blades are properly attached over the pins.
- 4. Check rear shell bearing for signs of wear (excessive mix leakage in rear drip pan) and be certain it is properly cleaned.
- 5. Using a screwdriver and cloth towel, keep the rear shell bearing and the female hex drive socket clean and free of lubricant and mix deposits.
- 6. Dispose of o-rings and seals if they are worn, torn or fit too loosely, and replace with new ones.
- 7. Follow all lubricating procedures as outlined in "Assembly."
- 8. Check the condensers for accumulation of dirt and lint. Dirty condensers will reduce the efficiency and capacity of the machine. Condensers should be cleaned **monthly** with a soft brush. **Never** use screwdrivers or other metal probes to clean between the fins.
- 9. On water cooled units, check the water lines for kinks or leaks. Kinks can occur when the machine is moved back and forth for cleaning or maintenance purposes. Deteriorated or cracked water lines should be replaced only by an authorized Taylor Company mechanic.



Operator's Troubleshooting Guide

PROBLEM	PROBABLE CAUSE	REMEDY	PAGE REFER.
1. No product being dispensed with draw valve open and control switch in "AUTO."	a. Assembled air tube not adjusted to the correct hole size for the product being used.	a. Adjust air tube assembly to the correct hole size.	—
	b. Freeze-up in mix inlet hole.	b. Contact service technician.	—
	c. Beater motor out on reset.	c. Reset freezer.	14
	d. Beater rotating counter-clockwise.	d. Contact service technician to correct rotation to clockwise.	—
	e. Circuit breaker off or blown fuse.	e. Turn breaker on or replace fuse.	—
	f. Inadequate mix in hopper.	f. Fill hopper with mix.	21
2. Product too cold.	a. Temperature control set too cold.	a. Adjust temperature control knob warmer.	15
	b. Draw handle not fully closed.	b. Draw handle must be fully closed.	—
3. Product too warm.	a. Temperature control set too warm.	a. Adjust temperature control knob colder.	15
	b. Loss of refrigerant.	b. Contact service technician.	—
4. Product appears too soft.	a. Worn scraper blades.	a. Replace regularly.	28
	b. Dirty condenser (A/C).	b. Clean regularly.	24
	c. Out-of-date mix.	c. Use only fresh mix.	—
	d. Beater rotating counter-clockwise.	d. Contact service technician to correct rotation to clockwise.	—
	e. Loss of water (W/C).	e. Locate cause of water loss and correct.	24
	f. Product broken down from overbeating.	f. Draw off some product to allow fresh product to enter freezing cylinder.	—
5. Mix in hopper too cold.	a. Temperature out of adjustment.	a. Contact service technician to adjust hopper temperature.	—
6. Mix in hopper too warm.	a. Temperature out of adjustment.	a. Contact service technician to adjust hopper temperature.	—
	b. Missing or defective hopper gasket.	b. Replace or install gasket around mix hopper.	20
	c. Hopper cover not in position.	c. Place cover in position.	21
	d. Control switch "OFF."	d. Place control switch in "AUTO."	21
	e. Warm mix placed in hopper.	e. Mix added to hopper must be below 40° F (4.4° C).	—
	f. Loss of refrigerant.	f. Contact service technician.	—

PROBLEM	PROBABLE CAUSE	REMEDY	PAGE REFER.
7. Drive shaft stuck in gear box coupling.	a. Rounded corners of drive shaft, coupling, or both.	a. Contact service technician to correct cause and replace the necessary components.	—
	b. Lubrication on hex end of drive shaft.	b. Do not lubricate hex end. Contact service technician for removal.	16
8. Freezing cylinder walls scored.	a. Scraper blades not installed over beater pins. Pins on beater broken.	a. Blades must fit over both pins on beater. Contact service technician to repair beater assembly.	17
	b. Beater assembly bent.	b. Contact service technician to repair or replace beater and to correct cause of insufficient mix in freezing cylinder.	—
	c. Missing or worn front bearing.	c. Install or replace front bearing.	17
9. Excessive mix leakage into rear drip pan.	a. Worn or missing drive shaft seal.	a. Replace regularly.	28
	b. Inadequate lubrication of drive shaft.	b. Lubricate properly.	16
	c. Worn rear shell bearing.	c. Contact service technician to replace rear shell bearing.	—
	d. Drive shaft works forward.	d. Contact service technician to correct.	—
	e. Seal installed inside-out on drive shaft.	e. Install correctly.	16
	f. Wrong type lubricant being used (Example: petroleum base lubricant).	f. Use proper lubricant (Example: Taylor Lube or Petro Gel).	16
10. Excessive mix leakage from door spout.	a. Worn or missing draw valve o-rings.	a. Replace regularly.	28
	b. Inadequate lubrication on draw valve o-rings.	b. Lubricate properly.	18
	c. Wrong type lubricant being used (Example: petroleum base lubricant).	c. Use proper lubricant (Example: Taylor Lube or Petro Gel).	16
11. No freezer operation with control switch in "AUTO."	a. Store circuit breaker off or blown fuse.	a. Turn circuit breaker on or replace fuse.	—
	b. Beater motor out on reset.	b. Reset freezer.	14

PROBLEM	PROBABLE CAUSE	REMEDY	PAGE REFER.
12. Low overrun.	<ul style="list-style-type: none"> a. Worn scraper blades. b. Air tube assembly not installed. c. Product broken down from overbeating. d. Assembled air tube not adjusted to the correct hole size for the product being used. 	<ul style="list-style-type: none"> a. Replace regularly. b. Install in mix inlet hole. c. Draw off some product to allow fresh product to enter the freezing cylinder. d. Adjust air tube assembly to the correct hole size. 	<ul style="list-style-type: none"> 28 21 — 21



Parts Replacement Schedule

ITEM	DESCRIPTION	EVERY 3 MONTHS	EVERY 6 MONTHS	ANNUALLY
1	Drive Shaft Seal	X		
2	Scraper Blade		Inspect & Replace if Necessary	Minimum
3	Freezer Door O-Ring	X		
4	Front Bearing	X		
5	Draw Valve O-Ring	X		
6	Pivot Pin O-Ring	X		
7	Design Cap	X		
8	White Bristle Brush, 3" x 7"		Inspect & Replace if Necessary	Minimum
9	White Bristle Brush, 1" x 2"		Inspect & Replace if Necessary	Minimum
10	Black Bristle Brush, 1" x 2"		Inspect & Replace if Necessary	Minimum
11	Double-Ended Brush		Inspect & Replace if Necessary	Minimum

Refer to Parts List on page 29 when ordering above parts.

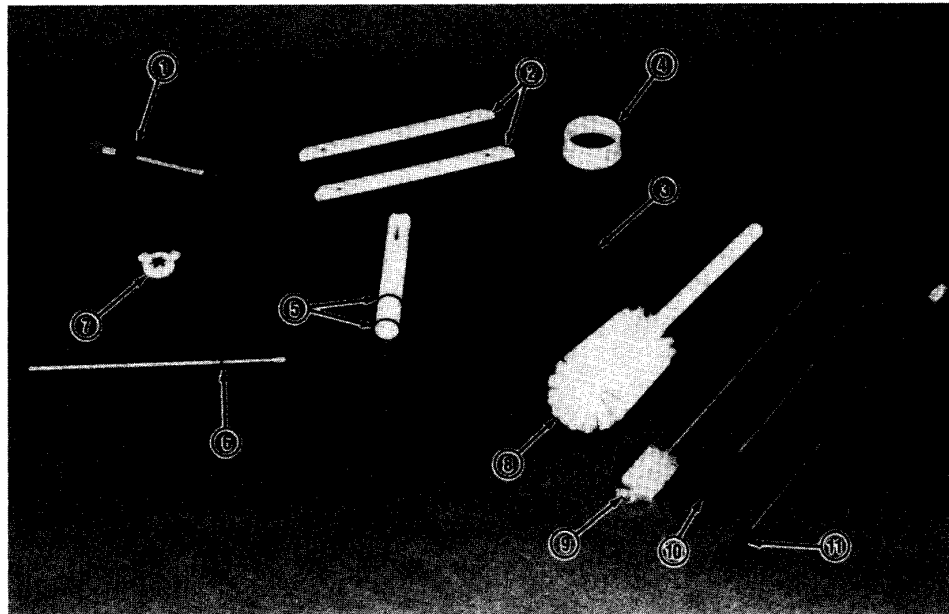

"Mr. Taylor" Tune-Up Kits are available from your Taylor Distributor. Keep your freezer in top condition with the above replacement parts in a Tune-Up Kit for your Model of freezer! Ask your Taylor Distributor about the Automatic 3-month Tune-Up Kit Mailing Program.



Parts List

Model 771C/770C

SPECIFY MODEL AND SERIAL NUMBERS WHEN ORDERING PARTS.

DESCRIPTION	PART NUMBER	771C QTY.	770C QTY.	WARR. CLASS
Adaptor-Spout	044196	2	2	C
Adaptor A-Caster	X18915	4	4	B
Bearing-Rear Shell	031324	2	2	C
+Guide-Drip	028992	2	2	C
+Nut-Brass Bearing	028991	2	2	C
+Washer-Bearing	012864	2	2	C
Beater Assembly	X44442	2	2	B
+Blade-Scraper	024785	4	4	C
Pin-Scraper Blade	014126	2	2	C
Pin-Scraper Blade	009839	6	6	C
Belt	023027	4		C
Belt	023875		4	C
Block-Terminal	039424	2		B
Block-Terminal	039423		2	B
Blower	012796-	1	1	B
+Guard-Blower	022505	1	1	B
Breaker-Circuit	043960	2		B
Brush-Black Bristle (1" x 2")	013071	1	1	C
Brush-Double End	013072	1	1	C
Brush-White Bristle (1-1/2" x 2")	014753	1	1	C
Brush-White Bristle (3" x 7")	023316	1	1	C
Caster-Swivel	018794	4	4	B
Compressor	031645-	2	2	*
Condenser	031651	2	2	B
Control-Mix Level	031799-	2	2	B
Control A-Temperature	X14383	2	2	B
Cover-Switch	022614		1	B
Cover A-Mix Hopper	X38458	2	2	B
+Gasket-Hopper	038474	1	1	C
Knob-Cover	025429	2	2	B
Decal-Clean & Sanitize	019029	1	1	C
Decal-Decorative Carvel	044576	1	1	C

*See Taylor Warranty Card
+Sold Separately

**SPECIFY VOLTAGE, CYCLE & PHASE OF FREEZER
WHEN ORDERING ELECTRICAL REPLACEMENT PARTS.**

DESCRIPTION	PART NUMBER	771C QTY.	770C QTY.	WARR. CLASS
Decal-Troubleshooting	038374	1	1	C
Decal-"Warm-Cold"	013749	2	2	C
Decal-Warning	036529	3	3	C
Diagram-Wiring	044193-	1		C
Diagram-Wiring	044230-		1	C
Door A-Freezer	X44163	1	1	B
+Bearing-Front	013116	2	2	C
+Cap-Design	043513	3	3	C
+Decal-Door	044577	1	1	C
+O-Ring-Door	044426	2	2	C
Dryer-Filter	026270	2	2	C
Element-Heater	014174-	4	4	C
Faucet	016778	1	1	B
Gear-Reducer	044172	2	2	*
Guide A-Drip Pan	X28698	2	2	B
Handle A-Draw	X44168	3	3	B
Handle-Adjustable	044169	3	3	B
Screw-Adjustment	026592	3	3	C
O-Ring	015872	3	3	C
Handscrew	034382	4	4	B
Hood	044162	1		B
Hood	044466		1	B
Kit A-Tune Up	X44316	1	1	C
Bearing-Front	013116	2	2	C
Cap-Design	043513	3	3	C
O-Ring (for Draw Valve)	020571	6	6	C
O-Ring (for Freezer Door)	044426	2	2	C
O-Ring (for Pivot Pin)	016272	1	1	C
Seal-Drive Shaft	032560	2	2	C
Knob-Temperature Control	013731	2	2	B
Label-Taylor Overload Chart	023489-1	1	1	C
Light-Dial	014118	2	2	B

*See Taylor Warranty Card
+Sold Separately

**SPECIFY VOLTAGE, CYCLE & PHASE OF FREEZER
WHEN ORDERING ELECTRICAL REPLACEMENT PARTS.**

DESCRIPTION	PART NUMBER	771C QTY.	770C QTY.	WARR. CLASS
Light-Mix Level Indicator	023056-	2	2	B
Line A-Water	X44318	1		B
Line A-Water	X44319	1		B
Line A-Water	X16798		2	B
Louver-Side	017471	2	2	B
Lubricant-Taylor	019680	1	1	C
Motor-Beater (3.0 HP)	031398-	2	2	*
Pail (10 Qt. - 9.5 Liter)	013163	1	1	C
Pan-Rear Drip	027503	2	2	B
Panel-Left Upper Side	044130	1		B
Panel-Left Upper Side	028700		1	B
Panel-Lower Front	044161	1		B
Panel-Rear	044160	1		B
Panel-Rear	017563		1	B
Panel-Right Upper Side	044131	1		B
Panel-Right Upper Side	028701		1	B
Panel-Service	024439		1	B
Panel A-Front	X15575		1	B
Panel A-Lower Side	X44138	2		B
Panel A-Lower Left Side	X44853		1	B
Panel A-Lower Right Side	X44855		1	B
Panel A-Upper Front	X44133	1		B
Pin A-Pivot	X44320	1	1	B
+O-Ring	016272	1	1	C
Plate-Decorative	044137	1		B
Plate-Faucet	016796	1	1	B
Plug-Drip Tray Hole	029595		1	C
Probe A-Mix	X30922	2	2	B
+Disc-Probe	030965	2	2	B
+Spacer-Probe	030966	2	2	B
Pulley-Beater Motor	017478	2	2	B
Pulley-Gear	027822	2	2	B

*See Taylor Warranty Card
+Sold Separately

**SPECIFY VOLTAGE, CYCLE & PHASE OF FREEZER
WHEN ORDERING ELECTRICAL REPLACEMENT PARTS.**

DESCRIPTION	PART NUMBER	771C QTY.	770C QTY.	WARR. CLASS
Relay-Compressor	012725-	2	2	B
Sanitizer-Kay-5	041082	1	1	C
Shaft-Beater Drive	044443	2	2	B
+Seal	032560	2	2	C
Shell A-Insulated	X44173	1	1	*
Shield-Splash	022766		1	B
Starter-Beater Line	014164-	2	2	B
Stud-Nose Cone	022822	4	4	B
Switch-Control	014237	2	2	B
+Card-Wash-Off-Auto	014091	2	2	C
Switch-High Pressure	030886	2	2	B
+Boot-Pressure Switch	034682	2	2	C
Switch A-Draw	X44190	1	1	B
Arm A-Draw	X44191	1	1	B
Pin-External Cotter	014051	1	1	C
Pin-Pivot	015478	1	1	B
Spring-Return	015342	1	1	B
Switch-Micro	009367	2	2	B
Switch A-Draw	X44323	2	2	B
Arm A-Draw	X44191	2	2	B
Pin-External Cotter	014051	2	2	C
Pin-Pivot	015478	2	2	B
Spring-Return	015342	2	2	B
Switch-Micro	009367	2	2	B
Tee-Access	026689	2	2	B
Transformer	016352-	2	2	B
Tray-Drip	014533		1	B
Trim-Left Rear Corner	044128	1		B
Trim-Left Rear Corner	013761		1	B
Trim-Right Rear Corner	044129	1		B
Trim-Right Rear Corner	013663		1	B
Tube A-Capillary	X44189	2		B

*See Taylor Warranty Card
+Sold Separately

**SPECIFY VOLTAGE, CYCLE & PHASE OF FREEZER
WHEN ORDERING ELECTRICAL REPLACEMENT PARTS.**

DESCRIPTION	PART NUMBER	771C QTY.	770C QTY.	WARR. CLASS
Tube A-Capillary	X22751		2	B
Tube A-Inner	X37379	2	2	B
Tube A-Outer	X14440	2	2	B
Valve-Access	029406	2	2	B
Valve-Automatic Expansion	037392	2	2	B
+Boot-Expansion Valve	027137	2	2	C
Valve-Check	027483	2	2	B
Valve-EPR	022665	2	2	B
Valve-Rotolock	023604	2	2	B
Valve-Water	008363	2	2	B
Valve A-Draw	X44166	3	3	B
+O-Ring	020571	6	6	C
OPTIONAL FEATURES				
AIR COOLED LOW CAPACITY				
Blower Assembly	X30153-		1	B
Housing A-W/Wheel	X30160		1	B
Motor-Blower	030157-		1	B
Compressor	038144-		2	*
Condenser	019558		2	B
Control-Fan Pressure	011163		1	B
Tee-Access	026688		4	B
Tee-Access	034665		2	B
Valve-Access	043232		2	B
WATER COOLED LOW CAPACITY				
Compressor	038144-		2	*
Condenser	018278		2	B
Tee-Access	042848		2	B
Valve-Access	043232		2	B

*See Taylor Warranty Card
 +Sold Separately

**SPECIFY VOLTAGE, CYCLE & PHASE OF FREEZER
 WHEN ORDERING ELECTRICAL REPLACEMENT PARTS.**

WIRING DIAGRAM MODEL 771C

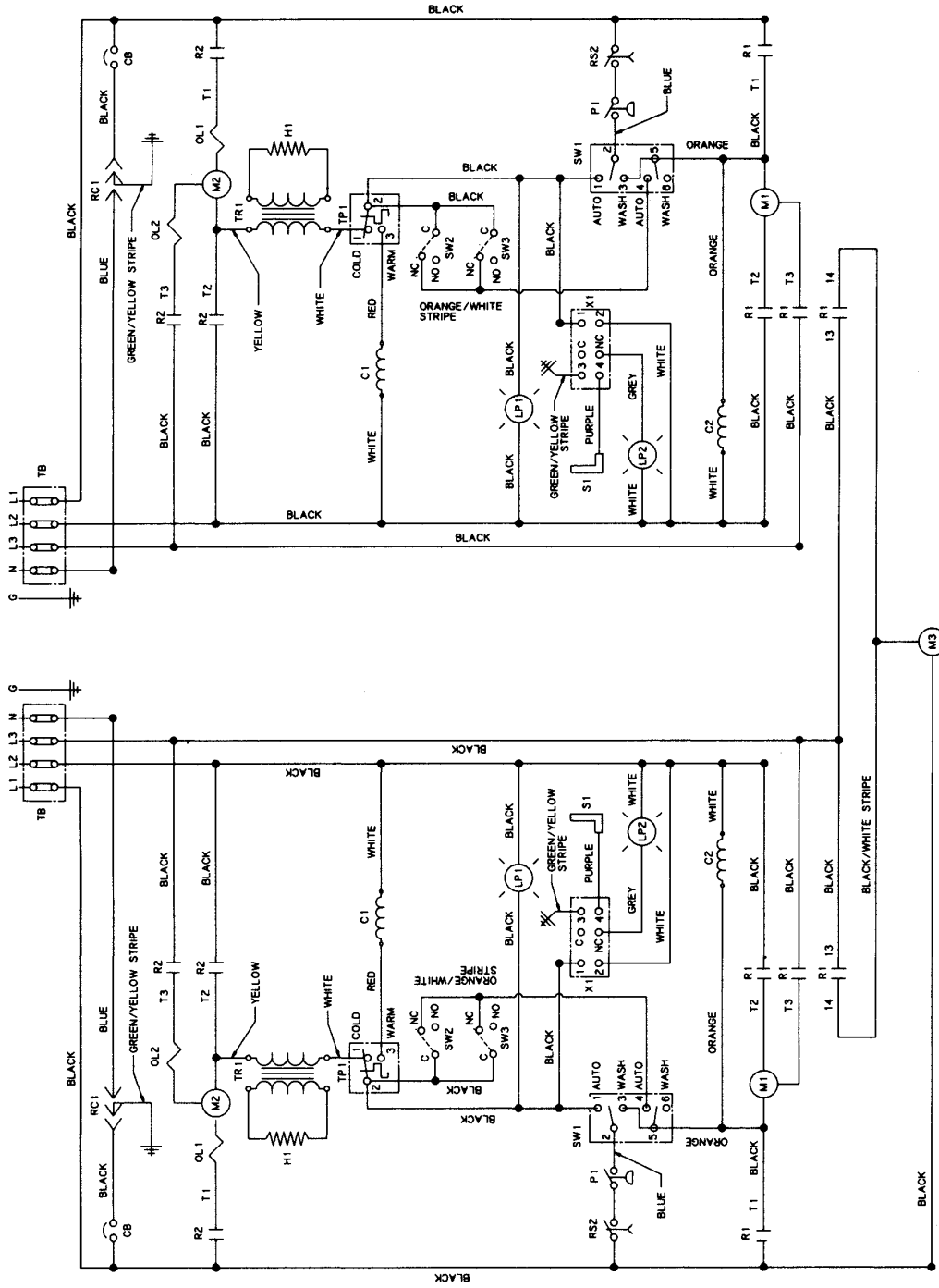

SYMBOL	LEGEND
CB	CIRCUIT BREAKER 15 AMPS
C1	COIL-COMPRESSOR MOTOR
C2	COIL-BEATER MOTOR
G	GROUND LUG
H1	ANTICIPATOR-HEATING COIL
LP1	LAMP-POWER AUTO ON
LP2	LAMP-MIX LOW
L1, L2	POWER SUPPLY-208/230V, 3 PHASE.
L3, N	4 POLE, 5 WIRE GROUNDING
M1	COMPRESSOR MOTOR
M2	BEATER MOTOR
M3	BLOWER MOTOR
OL1	THERMAL OVERLOAD-BEATER MOTOR
OL2	THERMAL OVERLOAD-BEATER MOTOR
P1	SWITCH-HI PRESSURE LIMIT-COMPRESSOR
RC1	RECEPTACLE
RS2	SWITCH-RESET-BEATER MOTOR
R1	RELAY-COMPRESSOR MOTOR-4 POLE
R2	RELAY-BEATER MOTOR
SW1	SWITCH-POWER-DPDT
SW2	SWITCH-DRAW
SW3	SWITCH-DRAW
S1	SENSOR-MIX LEVEL
TB	TERMINAL BLOCK
TP1	CONTROL-TEMPERATURE
TR1	TRANSFORMER-ANTICIPATOR-230V/24V
T1, T2, T3, T4	RELAY TERMINALS
X1	CONTROL-MIX LEVEL

CAUTION

INSTALLER NOTE: SUPPLY VOLTAGE BETWEEN TERMINALS MARKED "L1 AND N" MUST BE 115 VOLTS OR ELSE SERIOUS DAMAGE COULD OCCUR. SUPPLY VOLTAGE BETWEEN TERMINALS "L1 AND L2" AND "L3 AND L1" MUST BE 208-230 VOLTS

GROUND FRAME SECURELY

NO. 044193-33
3 PH.

WIRING DIAGRAM MODEL 770C

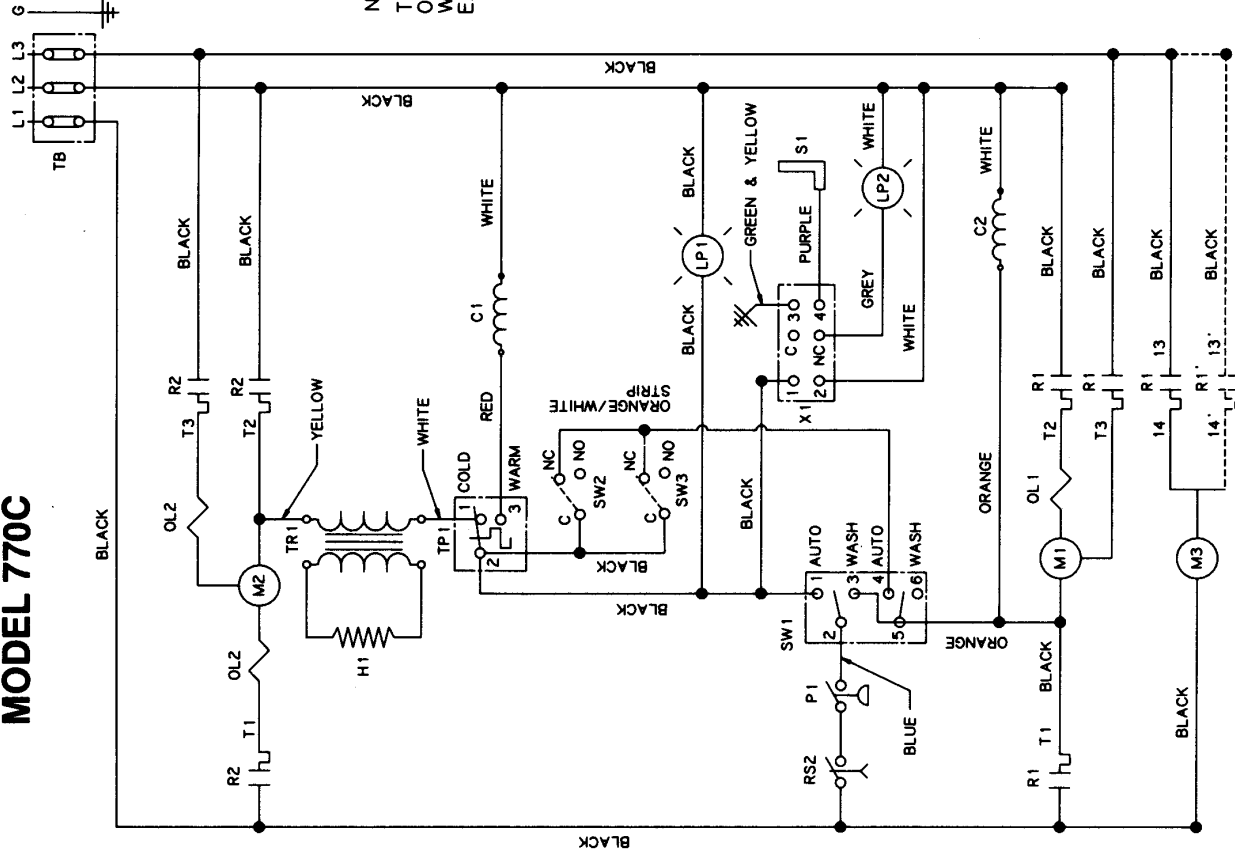

NOTE:
THIS WIRING IS REPEATED FOR
OTHER SIDE OF THE MODEL
WITH 2ND POWER SUPPLY
EXCEPT FOR M3 BLOWER MOTOR

SYMBOL	LEGEND
C1	COIL-COMPRESSOR MOTOR
C2	COIL-BEATER MOTOR
G	GROUND LUG
H1	ANTICIPATOR-HEATING COIL
LP1	LAMP-POWER AUTO ON
LP2	LAMP-MIX LOW
L1, L2, L3	POWER SUPPLY-208/230V, 3 PHASE, 3 POLE, 4 WIRE GROUND
M1	COMPRESSOR MOTOR
M2	BEATER MOTOR
M3	BLOWER MOTOR
OL1	THERMAL OVERLOAD-BEATER MOTOR
OL2	THERMAL OVERLOAD-BEATER MOTOR
P1	SWITCH-HI PRESSURE LIMIT-COMPRESSOR
RS2	SWITCH-RESET-BEATER MOTOR
R1	RELAY-COMPRESSOR MOTOR-4 POLE
R1'	RELAY-COMPRESSOR MOTOR-4 POLE FROM SECOND POWER SUPPLY
R2	RELAY-BEATER MOTOR
SW1	SWITCH-POWER-DPDT
SW2	SWITCH-DRAW
SW3	SWITCH-DRAW
S1	SENSOR-MIX LEVEL
TB	TERMINAL BLOCK
TP1	CONTROL-TEMPERATURE
TR1	TRANSFORMER-ANTICIPATOR-230V/24V
T1, T2, T3, T4	RELAY TERMINALS
X1	CONTROL-MIX LEVEL



Notes

